

ロングハーフユニオン SB

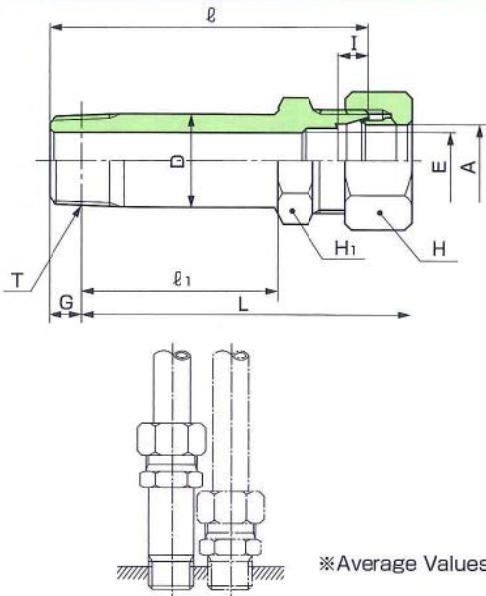

使用例

※Average Values

| 継手の呼び         | 適用管外径A |       | (PT) | E     | 基準径の位置G | 六角対辺           |     | I    | D    | ℓ    | ℓ <sub>1</sub> | 手締めL(約) |
|---------------|--------|-------|------|-------|---------|----------------|-----|------|------|------|----------------|---------|
|               | 呼び径    | 外径    |      |       |         | H <sub>1</sub> | H   |      |      |      |                |         |
| SB - 4×1/8    | 4      | 1/8   | 2.5  | 3.97  | 12      | 12             | 6   | 10.5 | 46   | 30   | 49.5           |         |
| SB - 6×1/8    | 6      | 1/8   | 4    | 3.97  | 14      | 14             | 7   | 10.5 | 63   | 41   | 69.5           |         |
| SB - 8×1/4    | 8      | 1/4   | 6    | 6.01  | 17      | 17             | 7   | 14   | 70   | 45   | 74.5           |         |
| SB - 10×1/4   | 10     | 1/4   | 7    | 6.01  | 17      | 19             | 7   | 14   | 71   | 46   | 76.5           |         |
| SB - 10×3/8   | 10     | 3/8   | 8    | 6.35  | 19      | 19             | 7   | 17.5 | 72   | 46.5 | 77             |         |
| SB - 12×1/4   | 12     | 1/4   | 7    | 6.01  | 19      | 22             | 7   | 14   | 71   | 46   | 76.5           |         |
| SB - 12×3/8   | 12     | 3/8   | 9    | 6.35  | 19      | 22             | 7   | 17.5 | 72   | 46.5 | 77             |         |
| SB - 15×3/8   | 15     | 3/8   | 9    | 6.35  | 24      | 27             | 7.5 | 17.5 | 81   | 52.5 | 87             |         |
| SB - 15×1/2   | 15     | 1/2   | 12   | 8.16  | 24      | 27             | 7.5 | 22   | 86   | 56   | 90.5           |         |
| SB - 16×1/2   | 16     | 1/2   | 12   | 8.16  | 27      | 30             | 7.5 | 22   | 86   | 56   | 90.5           |         |
| SB - 18×1/2   | 18     | 1/2   | 12   | 8.16  | 27      | 32             | 8   | 22   | 86   | 56   | 90.5           |         |
| SB - 20×3/4   | 20     | 3/4   | 16   | 9.53  | 30      | 36             | 8   | 27.5 | 92   | 58.5 | 95             |         |
| SB - 22×3/4   | 22     | 3/4   | 16   | 9.53  | 32      | 36             | 9   | 27.5 | 93   | 59.5 | 96             |         |
| SB - 25×1     | 25     | 1     | 20   | 10.39 | 36      | 41             | 10  | 34   | 99   | 63.5 | 102            |         |
| SB - 28×1     | 28     | 1     | 22   | 10.39 | 41      | 46             | 10  | 34   | 104  | 65   | 107.5          |         |
| SB - 30×1 1/4 | 30     | 1 1/4 | 25   | 12.70 | 46      | 46             | 10  | 42.5 | 109  | 68.5 | 111            |         |
| SB - 32×1 1/4 | 32     | 1 1/4 | 26   | 12.70 | 46      | 50             | 11  | 42.5 | 110  | 69.5 | 112            |         |
| SB - 1/8×1/4  | 1/8    | 10.5  | 1/4  | 7     | 6.01    | 17             | 19  | 7    | 14   | 71   | 46             | 76.5    |
| SB - 1/4×3/8  | 1/4    | 13.8  | 3/8  | 9     | 6.35    | 22             | 24  | 7.5  | 17.5 | 81   | 52.5           | 86.5    |
| SB - 3/8×3/8  | 3/8    | 17.3  | 3/8  | 9     | 6.35    | 27             | 32  | 8    | 17.5 | 81   | 52.5           | 87      |
| SB - 3/8×1/2  | 3/8    | 17.3  | 1/2  | 12    | 8.16    | 27             | 32  | 8    | 22   | 86   | 56             | 90.5    |
| SB - 1/2×3/4  | 1/2    | 21.7  | 3/4  | 16    | 9.53    | 32             | 36  | 9    | 27.5 | 93   | 59.5           | 96      |
| SB - 3/4×1    | 3/4    | 27.2  | 1    | 22    | 10.39   | 41             | 46  | 10   | 34   | 104  | 66.5           | 107.5   |

※上記諸元は品質の向上により若干変わることがあります。

ハーフユニオン (PF) SO

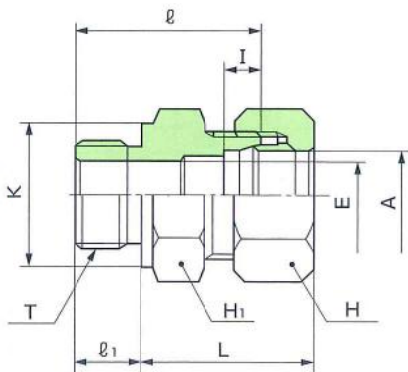

※Average Values

| 継手の呼び            | 適用管外径A |       | (PF)  | E  | 六角対辺           |     | I   | K  | ℓ <sub>1</sub> | ℓ    | 手締めL(約) |
|------------------|--------|-------|-------|----|----------------|-----|-----|----|----------------|------|---------|
|                  | 呼び径    | 外径    |       |    | H <sub>1</sub> | H   |     |    |                |      |         |
| SO - 4×1/8       | 4      | 1/8   | 2.5   | 14 | 12             | 6   | 14  | 8  | 23             | 22.5 |         |
| SO - 6×1/8       | 6      | 1/8   | 4     | 14 | 14             | 7   | 14  | 8  | 28             | 30.5 |         |
| SO - 6×1/4       | 6      | 1/4   | 4     | 19 | 14             | 7   | 19  | 12 | 33             | 31.5 |         |
| SO - 8×1/8       | 8      | 1/8   | 4     | 17 | 17             | 7   | 14  | 8  | 28             | 30.5 |         |
| SO - 8×1/4       | 8      | 1/4   | 6     | 19 | 17             | 7   | 19  | 12 | 33             | 31.5 |         |
| SO - 10×1/4      | 10     | 1/4   | 6     | 19 | 19             | 7   | 19  | 12 | 33             | 32.5 |         |
| SO - 10×3/8      | 10     | 3/8   | 8     | 22 | 19             | 7   | 22  | 12 | 34             | 33.5 |         |
| SO - 12×1/4      | 12     | 1/4   | 6     | 19 | 22             | 7   | 19  | 12 | 33             | 32.5 |         |
| SO - 12×3/8      | 12     | 3/8   | 8     | 22 | 22             | 7   | 22  | 12 | 34             | 33.5 |         |
| SO - 12×1/2      | 12     | 1/2   | 10    | 27 | 22             | 7   | 27  | 14 | 39             | 36.5 |         |
| SO - 15×3/8      | 15     | 3/8   | 8     | 24 | 27             | 7.5 | 22  | 12 | 37             | 37.5 |         |
| SO - 15×1/2      | 15     | 1/2   | 12    | 27 | 27             | 7.5 | 27  | 14 | 41             | 39.5 |         |
| SO - 16×1/2      | 16     | 1/2   | 12    | 27 | 30             | 7.5 | 27  | 14 | 41             | 39.5 |         |
| SO - 18×1/2      | 18     | 1/2   | 12    | 27 | 32             | 8   | 27  | 14 | 41             | 39.5 |         |
| SO - 20×3/4      | 20     | 3/4   | 16    | 36 | 36             | 8   | 36  | 16 | 46             | 42.5 |         |
| SO - 22×1/2      | 22     | 1/2   | 12    | 32 | 36             | 9   | 27  | 14 | 43             | 41.5 |         |
| SO - 22×3/4      | 22     | 3/4   | 16    | 36 | 36             | 9   | 36  | 16 | 46             | 42.5 |         |
| SO - 25×3/4      | 25     | 3/4   | 16    | 36 | 41             | 10  | 36  | 16 | 46             | 43.5 |         |
| SO - 25×1        | 25     | 1     | 20    | 41 | 41             | 10  | 41  | 18 | 50             | 45.5 |         |
| SO - 28×1        | 28     | 1     | 22    | 41 | 46             | 10  | 41  | 18 | 52             | 48   |         |
| SO - 30×1        | 30     | 1     | 22    | 41 | 46             | 10  | 41  | 18 | 52             | 48.5 |         |
| SO - 30×1 1/4    | 30     | 1 1/4 | 25    | 50 | 46             | 10  | 50  | 20 | 57             | 51.5 |         |
| SO - 32×1 1/4    | 32     | 1 1/4 | 26    | 50 | 50             | 11  | 50  | 20 | 57             | 51.5 |         |
| SO - 35×1 1/4    | 35     | 1 1/4 | 28    | 50 | 55             | 11  | 50  | 20 | 57             | 54.5 |         |
| SO - 38×1 1/2    | 38     | 1 1/2 | 32    | 55 | 60             | 12  | 55  | 21 | 58             | 56.5 |         |
| SO - 40×1 1/2    | 40     | 1 1/2 | 32    | 55 | 60             | 12  | 55  | 21 | 62             | 60.5 |         |
| SO - 42×1 1/2    | 42     | 1 1/2 | 34    | 55 | 60             | 12  | 55  | 21 | 62             | 60.5 |         |
| SO - 50×2        | 50     | 2     | 40    | 75 | 75             | 12  | 75  | 25 | 73             | 69.5 |         |
| SO - 1/8×1/8     | 1/8    | 10.5  | 1/8   | 4  | 17             | 19  | 7   | 14 | 8              | 29   | 32.5    |
| SO - 1/8×1/4     | 1/8    | 10.5  | 1/4   | 6  | 19             | 19  | 7   | 19 | 12             | 33   | 32.5    |
| SO - 1/4×1/4     | 1/4    | 13.8  | 1/4   | 6  | 22             | 24  | 7.5 | 19 | 12             | 36   | 36      |
| SO - 1/4×3/8     | 1/4    | 13.8  | 3/8   | 8  | 22             | 24  | 7.5 | 22 | 12             | 36   | 36      |
| SO - 3/8×3/8     | 3/8    | 17.3  | 3/8   | 8  | 27             | 32  | 8   | 22 | 12             | 38   | 38.5    |
| SO - 3/8×1/2     | 3/8    | 17.3  | 1/2   | 12 | 27             | 32  | 8   | 27 | 14             | 41   | 39.5    |
| SO - 1/2×1/2     | 1/2    | 21.7  | 1/2   | 12 | 32             | 36  | 9   | 27 | 14             | 43   | 41.5    |
| SO - 1/2×3/4     | 1/2    | 21.7  | 3/4   | 16 | 36             | 36  | 9   | 36 | 16             | 46   | 42.5    |
| SO - 3/4×3/4     | 3/4    | 27.2  | 3/4   | 16 | 41             | 46  | 10  | 36 | 16             | 50   | 48      |
| SO - 3/4×1       | 3/4    | 27.2  | 1     | 22 | 41             | 46  | 10  | 41 | 18             | 52   | 48      |
| SO - 1×1         | 1      | 34.0  | 1     | 22 | 46             | 55  | 11  | 41 | 18             | 54   | 53.5    |
| SO - 1×1 1/4     | 1      | 34.0  | 1 1/4 | 28 | 50             | 55  | 11  | 50 | 20             | 57   | 54.5    |
| SO - 1 1/4×1 1/4 | 1 1/4  | 42.7  | 1 1/4 | 31 | 60             | 65  | 12  | 50 | 20             | 63   | 63.5    |
| SO - 1 1/4×1 1/2 | 1 1/4  | 42.7  | 1 1/2 | 34 | 60             | 65  | 12  | 55 | 21             | 64   | 63.5    |
| SO - 1 1/2×1 1/2 | 1 1/2  | 48.6  | 1 1/2 | 36 | 65             | 75  | 12  | 55 | 21             | 65   | 63.5    |
| SO - 1 1/2×2     | 1 1/2  | 48.6  | 2     | 40 | 75             | 75  | 12  | 75 | 25             | 73   | 69.5    |

注：1.対応するパッキンはOリング、ポンデッドシールが使用できます。  
 ※上記諸元は品質の向上により若干変わることがあります。