

# 15MPa B型銅管くい込継手 (150kgf/cm<sup>2</sup>)

## GU-1型

### UNION

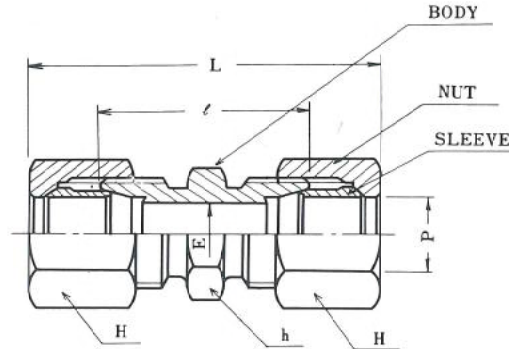
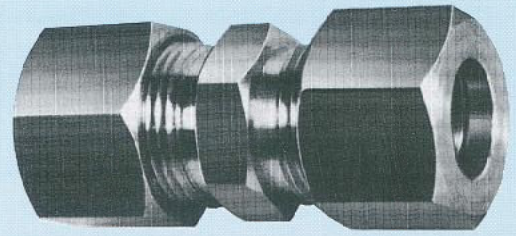

(注) L寸法はナットを締付け前の概略寸法を示す。

L denotes the rough dimensions before tightening the nuts. 単位：mm

継手の呼称 Designation of Joints	各部の記号 Symbols of respective parts	適用する 管の外径 Tube (O.D.) P	Minimum Opening E	六角対辺 Opposite sides of hexagon		ℓ	(約) Approx L	1組分Wt Weight per set (kg)
				h	H			
Gu-1 4-B	4-B	4	2.5	12	12	20	36	0.024
Gu-1 6-B	6-B	6	4	14	14	30	48.5	0.048
Gu-1 8-B	8-B	8	6	17	17	31	51	0.064
Gu-1 10-B	10-B	10	8	17	19	31	53	0.082
Gu-1 12-B	12-B	12	10	19	21	31	53	0.092
Gu-1 14-B	14-B	14	11	23	26	36	60	0.154
Gu-1 15-B	15-B	15	12	23	26	36	60	0.165
Gu-1 16-B	16-B	16	13	26	29	36	61	0.203
Gu-1 18-B	18-B	18	15	29	32	38	62	0.250
Gu-1 20-B	20-B	20	17	29	35	38	61.5	0.290
Gu-1 22-B	22-B	22	18	32	36	38	63	0.303
Gu-1 25-B	25-B	25	20	35	41	39	64	0.390
Gu-1 28-B	28-B	28	22	38	41	43	70	0.397
Gu-1 30-B	30-B	30	25	41	46	43	71	0.519
Gu-1 32-B	32-B	32	26	46	50	44	73	0.670
Gu-1 35-B	35-B	35	28	46	55	44	79	0.780
Gu-1 40-B	40-B	40	32	54	60	55	95.5	1.180
Gu-1 42-B	42-B	42	34	54	65	55	96	1.190
Gu-1 45-B	45-B	45	35	58	65	60	100.1	1.400
Gu-1 5-B	5-B	5	3	12	12	20	36	0.020
Gu-1 6.35-B	6.35-B	6.35	4	14	14	30	49	0.049
Gu-1 9.53-B	9.53-B	9.53	7.5	17	19	31	56	0.080
Gu-1 12.7-B	12.7-B	12.7	10	19	21	31	56	0.085
Gu-1 15.88-B	15.88-B	15.88	13	26	29	36	61	0.195
Gu-1 19.05-B	19.05-B	19.05	16	29	35	38	63	0.285
Gu-1 22.23-B	22.23-B	22.23	18	32	36	38	63	0.296
Gu-1 25.4-B	25.4-B	25.4	20	35	41	39	66	0.445
Gu-1 28.58-B	28.58-B	28.58	22	38	41	43	70	0.390